



Control Solutions



GE Fanuc
Intelligent Platforms

Power and Flexibility to Meet Your Automation Challenges

Delivering on Your Need to Improve Productivity and Profitability

In today's challenging economy, you're being asked to do more with less — to deliver better results and greater profitability with fewer resources.

And all this while adhering to increasingly demanding customer requirements and managing operations that are more global in nature. Now more than ever, you rely on control solutions that help you maximize your productivity and set you apart from your competitors.

Understanding the pressures that you face and building the hardware and software technologies that enable you to meet those challenges head-on is what we

do at GE Fanuc Intelligent Platforms. We have been delivering greater productivity, capacity and quality to our customers in diverse industries around the world for years — helping them gain a sustainable advantage.

Industry-Leading Quality and Innovation

- PACSystems* – combining flexibility, openness, and performance without the historical burden of migration path and conversion
- Ground-breaking programmable automation controller (PAC) concept—write your application once and use it on multiple hardware platforms

- Proven history of developing technology to give you superior power with unprecedented flexibility in system design
- Six Sigma design methodology for superior reliability

Get Just What You Need

- Fine-tune your system design to your exact performance requirements and budget
- An unparalleled variety of controller and I/O modules at a range of price points
- The power of customized solutions with the convenience and economy of off-the-shelf technology
- True hardware independence and your choice among PAC, PLC, or PC-based platforms
- Flexibility to grow as you grow, offering a range of options through the lifecycle of your applications





“By selecting GE Fanuc, we got a critical control solution that addresses the fundamental concern of maximizing uptime and improving production. In addition, we solved our parts availability issue because of the worldwide supply chain that comes with partnering with a GE company.”

Engineering Manager,
Elliott Turbomachinery Company, Inc.

One Development Tool for All Controls, All Applications, All Users

- Proficy Machine Edition – the universal development environment for all your operator interface, motion, and control applications. Includes Proficy Logic Developer (Control), Proficy Motion Developer (Motion), Proficy View (Operator Interface and HMI).
- Everything you need to configure, program, commission and maintain your applications through your full project lifecycle
- Reduce your training time with one software package for all controllers
- Designed for easy migration – use with today’s hardware platforms as well as the platforms of tomorrow
- Common editing tools, common database, and common objects shared across applications

Open, Scalable Systems – Protection for Your Investment

- Technology designed around recognized global standards and modular architecture, allowing you to avoid product obsolescence
- Seamless migration path to the very latest technology – layer on the latest solutions while protecting your investment in existing systems
- Freedom to upgrade or add on to your system easily as your needs change
- Easy integration with your installed base systems

The Strength of GE Fanuc Behind Every Solution

- Peace of mind in knowing you can rely on GE Fanuc controller solutions
- Long history as a leader in advanced technology for control and I/O, HMI, and operator interface
- Demonstrated record of quality and innovation
- Offering the worldwide strength and resources of GE while serving you with local supply and support
- Six Sigma quality built into all GE products

We Are Committed To Helping You Achieve Spectacular Control

With a Complete Range of Control Hardware Powered
by the Integrated Proficy* Machine Edition Software

With technology ranging from compact and economical micro controllers to cutting-edge programmable automation controllers and the open flexibility of our industrial PCs, GE Fanuc has a wide array of off-the-shelf solutions to meet your exact needs. And because we integrate these flexible automation products with powerful software that provides the universal engineering development environment for all our controllers, both your knowledge base and your applications are portable as you move from platform to platform and expand from generation to generation.



Simple Control

Small Control Systems for Standalone and Basic Applications

Durus* Controllers provide all-in-one control in a simple and rugged form. Its easy-to-use programming will have you running in no time.

The VersaMotion* family of servo amplifiers offers simple stand-alone positioning capability using up to eight stored motion profiles, or can be connected to any motion controller using an analog velocity, analog torque or pulse command interface.

VersaMax* Micro PLC offers the flexibility of modular design and a variety of built-in features, fast cycle times, a robust instruction set and extensive memory that multiplies your programming options.



Moderate Control

Versatile, Scalable Control Systems for a Variety of Mid-Range Applications

VersaMax offers big PLC power in a small package as well as a broad range of discrete, analog, mixed and specialty I/O modules.

With its modular design, over 100 I/O modules, and a range of CPU options, the Series 90*-30 PLC is versatile enough to configure a system based on your specific performance needs. Its superior networking and communications capabilities enable you to network, transfer data, upload and download programs and perform diagnostics over one non-proprietary network.

QuickPanel* Control provides access to a broad range of I/O, communicates via a variety of networks, and enables remote monitoring of your systems.

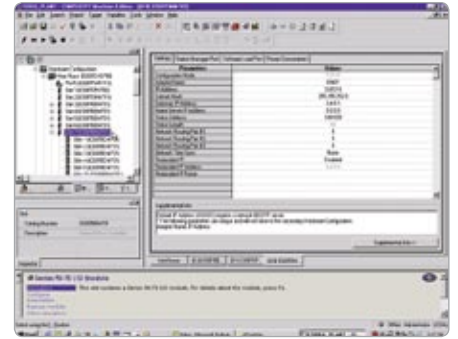

Complex Control

Powerful, Flexible Control Systems for Demanding Applications

The PACSystems family of controllers has application portability, enabling you to select one platform today and move to a higher-end system tomorrow by simply changing a few settings.

Both the VME-based RX7i and the PCI-based RX3i help you boost the overall speed, capacity and performance of your automation systems with powerful CPUs and high-bandwidth backplanes. Integrated motion control facilitates high performance point-to-point applications. Redundancy and High Availability are available in the RX3i and RX7i PACSystems.

The open architecture backplane of the Series 90-70 unlocks the versatility of hundreds of unique VME-based cards for applications involving elements such as vision, highly specialized motion, or fiber-optic networks.

A robust industrial PC offering enables you to design a solution uniquely suited to the needs of your control application.

Specialized Control

Advanced Control Systems for Critical and Resource-Intensive Applications

PACSystems offers enhanced speed and capacity over existing PLC technologies for high-speed processing and communications as well as memory-intensive tasks such as recipe storage and data-logging. The RX7i is ideally suited for integrated solutions that require open architecture, large memory, distributed I/O and high performance.

Coupled with the advanced diagnostic capabilities of Genius* I/O, Series 90-70 PLCs have become the industry standard for complex applications requiring redundancy, large numbers of I/O, and large amounts of process memory.

You can customize your system architecture even further with a variety of available VME-based single board computers (SBCs), I/O and specialty modules as well as motion controllers for a broad range of stand-alone or distributed system configurations.

Proficy Logic Developer PLC

All the Tools You Need to Develop, Monitor, and Troubleshoot Your Application Through the Entire Lifecycle of Your Project

Proficy Logic Developer PLC provides a complete set of programming languages for you to develop your control applications. User-defined function blocks let you develop and maintain code in one place but use it multiple times within and across your applications.

Configuration

Intuitive tools make it easy to configure the system and enhance and modify it as needed. One software package supports the full line of GE Fanuc controllers.

Commissioning

A complete set of online development tools can help you debug issues and solve problems more quickly, and the data monitoring tools provide a window into your application execution.

Monitoring

Access application data through the software, and control and monitor the system from any location using a web browser. Plus, there are a powerful variety of tools for charts, alarms, trends, and statistics.

Maintenance

The diagnostic tools help identify problems that may have occurred with your system. Additional features include central storage, version control, and access control capabilities.



A Complete Range of Control

Simple Control

- Minimal memory requirements
- Simple communications
- Typically fewer than 150 points of I/O
- Applications such as vending machines, low-end labeling and packaging, and dispensing

Products:

- Durus
- VersaMax PLC
- QuickPanel Control

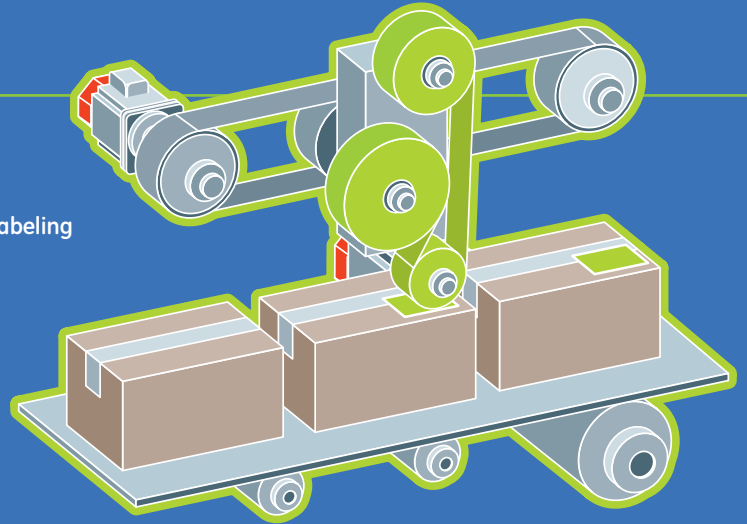

Complex Control

- High availability
- High-speed data transfer
- Integration with industry-standard technologies (PCI, VME)
- Typically 200 to 5,000 points of I/O
- Motion components
- Applications such as printing, flying shear, and winding machines

Products:

- Series 90-70 PLC
- PACSystems RX3i
- PACSystems RX7i

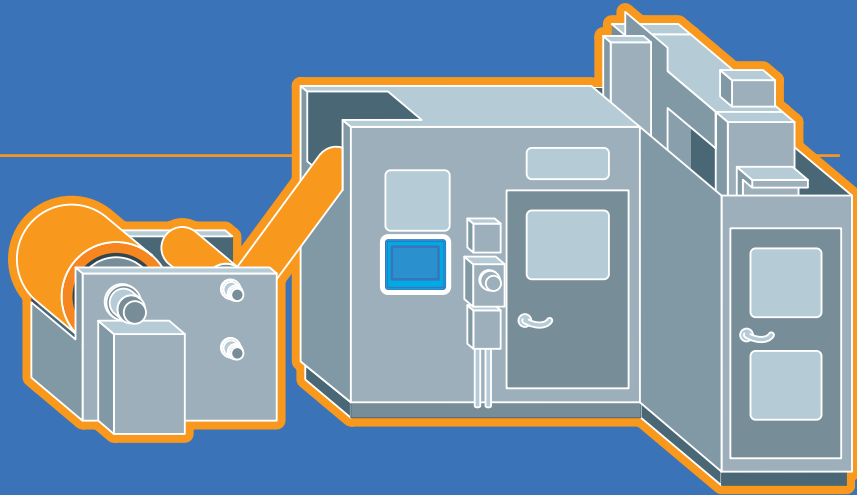

Moderate Control

- Expanded communication via Fieldbus (Genius, DeviceNet™, Profibus-DP™) and Ethernet interfaces
- Wide range of I/O requirements
- Typically between 150 and 512 points of I/O
- Applications such as food processing, semiconductor wafer fab, material handling, and plastic injection molding

Products:

- VersaMax PLC
- VersaMax Micro and Nano
- QuickPanel Control
- Series 90-30 PLC

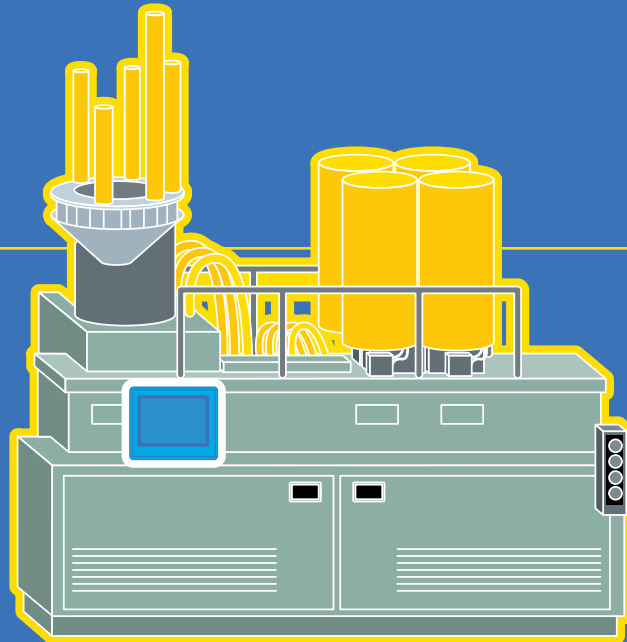

Specialized Control

- Memory intensive
- Coordinated control
- Genius Modular Redundancy
- Typically 1,000 or more points of I/O
- Applications such as SIL 1 and 2, automotive paint shop, fire and gas detection, reactor shutdown systems, and critical control

Products:

- Series 90-70 PLC
- PACSystems RX3i
- PACSystems RX7i

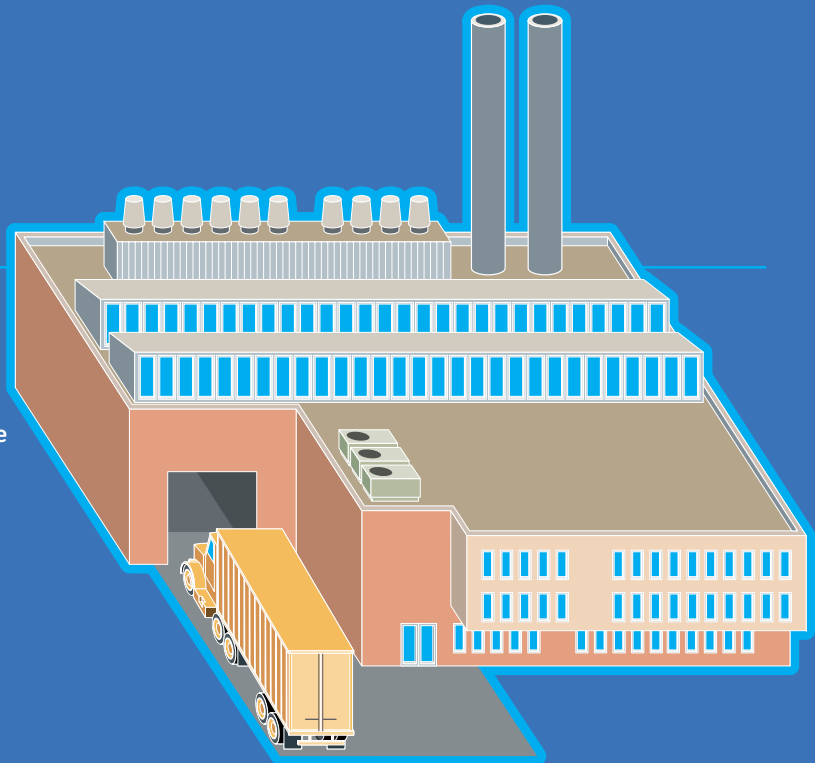



GE Fanuc Intelligent Platforms Information Center

Headquarters:
1 800 GEFANUC
1 800 322 3616
1 434 978 5100

Global Regional phone numbers
are available on our web site
www.gefanuc.com

Additional Resources

For more information, please visit the
GE Fanuc Intelligent Platforms web site at:

www.gefanuc.com

