

TEMPERATURE TRANSMITTERS

SEM206 TC

- K, J, N, E, T, R, S THERMOCOUPLES PLUS mV
- CONFIGURATION USING USB PORT POWERED CONFIGURATOR
- ISOLATED INPUT
- OVER RANGE LED INDICATION
- PROGRAMMABLE BURNOUT



INTRODUCTION

The SEM206/TC is a cost effective “smart” in head transmitter that accepts thermocouple temperature sensors and converts sensor output over a configured range to a standard industrial (4 to 20) mA transmission signal.

PC configuration allows the user to select TC type, Range, units and Burnout direction, without requiring calibration equipment. Configuration is performed quickly using a our new USB port driven configurator by simply connecting two clips to the SEM206TC loop terminals and following the software instructions. Calibration set up may be saved as a file on the PC for later use.

The SEM206 TC in head transmitter incorporates the latest digital technology to ensure accurate drift free performance.

If required the desired range can be specified at the time of order, removing the need for user configuration.
If the range is not specified then the transmitter will be shipped with the default range of 0 to 1000 °C type K.

CONFIGURATION METHOD

EQUIPMENT

COMPUTER	Running Windows XP or later with USB port
USB CONFIGURATOR SUITE	Comprising: USB Configurator, Leads and Pen Drive with S/W

METHOD

- Load PC with USB_LINK software.
- Connect USB Configurator to PC USB port using cable.
- Connect Tool clips to SEM206 Loop Terminals Red (+) Black (-)
- Run software, set configuration required and save to device.

SPECIFICATIONS @ 20 ° C

INPUT

Sensor	Range (°C)	Accuracy
K	-200 to 1370	± 0.1% of F.S. ± 0.5 °C (plus any sensor error)
J	-100 to 1200	± 0.1% of F.S. ± 0.5 °C (plus any sensor error)
E	-200 to 1000	± 0.1% of F.S. ± 0.5 °C (plus any sensor error)
N	-180 to 1300	± 0.1% of F.S. ± 0.5 °C (plus any sensor error)
T	-200 to 400	± 0.2% of F.S. ± 0.5 °C (plus any sensor error)
R	-10 to 1760	± 0.1% of F.S. ± 0.5 °C over the range 800 to 1600 (plus any sensor error)
S	-10 to 1760	± 0.1% of F.S. ± 0.5 °C over the range 800 to 1600 (plus any sensor error)
	Range (mV)	
mV	-10 to 70	± 0.02 % of full scale

Isolation	Tested to 250 V dc
Sensor Burnout	Either up or down scale output
Cold Junction	Range (-40 to 85) °C; Accuracy ±0.5 °C Tracking ± 0.05 °C / °C Offset 0.1 °C / °C
Stability	Span 0.05 °C / °C

TEMPERATURE TRANSMITTERS

OUTPUT

Output Type	2 wire (4 to 20) mA current loop
Output range	4.0 mA to 20.0 mA
Output Connection	Screw Terminal
Maximum output	21.5 mA (in high burnout condition)
Minimum output	3.8 mA (in low burnout condition)
Accuracy	(mA output / 2000) or 5 uA (Which ever is the greater)
Loop Voltage effect	$\pm 0.2 \text{ uA} / \text{V}$
Thermal drift	$\pm 1 \text{ uA} / ^\circ\text{C}$ Typically $\pm 1.5 \text{ uA}$
Maximum output load	$[(V_{\text{supply}} - 10) / 20] \text{ K Ohms}$ (Example 700 Ohms @ 24 V)

GENERAL SPECIFICATION

Update time	500 ms
Response Time	1 second
Start up time	4 seconds (Output < 4 mA during start up)
Warm-up time	1 minute to full accuracy
Power Supply	10 to 30 Volts dc

ENVIRONMENTAL

Ambient operating range	$(-40 \text{ to } +85) ^\circ\text{C}$
Ambient storage temperature	$(-50 \text{ to } +90) ^\circ\text{C}$
Ambient humidity range	(10 to 90) % RH non condensing

PHYSICAL

Dimensions	43 mm diameter; 21 mm height
Weight	31 g (encapsulated)

APPROVALS

EMC - BS EN 61326 :1998 -

Electrical equipment for measurement control and laboratory use.

ANNEX A

Immunity test requirements for equipment intended for use in industrial locations

ANNEX F

Test configurations, operational conditions and performance criteria for transducers with integrated or remote signal conditioning.

IEC 61000-4-2	Electrostatic discharge
IEC 61000-4-3	EM Field
IEC 61000-4-4	Transient Burst (output)
IEC 61000-4-5	Surge (output)

Note - Sensor input wires to be less than 3 metres to comply.

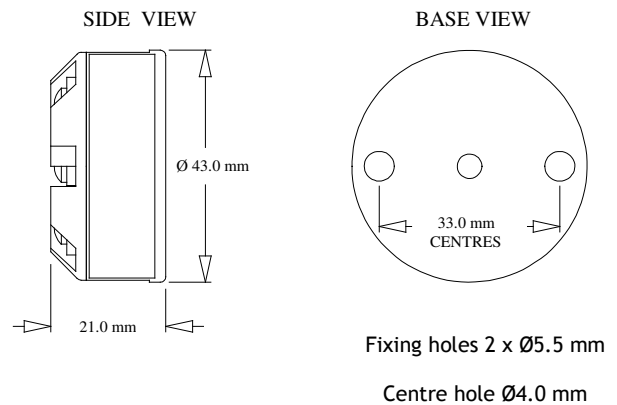

WIRING CONNECTIONS

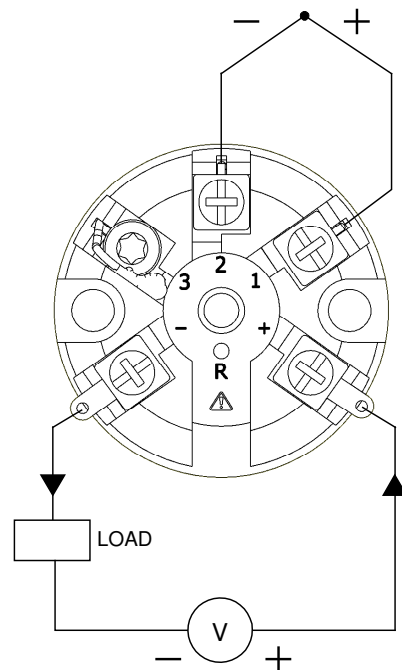

ORDER CODE:

SEM 206TC

ACCESSORIES:

USB CONFIGURATOR SUITE

USB-KIT